

JAOS REAR HATCH SPOILER Installation Instructions

Vehicle Application
LEXUS LX570 12+

Thank you for purchasing our rear hatch spoiler.
This manual describes how to install the rear hatch spoiler properly.
Read this manual thoroughly before installing the rear hatch spoiler.

INSTALLATION TIME  1.0-hours

TOOL **Phillips head screwdriver**
A pair of scissors
Masking tape
Drill(3.0mm/6.0mm/9.0mm)
Files

	Replacing / installing the parts	Easy
SKILL LEVEL	Doing body modifications	Moderately Easy
	Specialized knowledge required	Moderately Difficult
	Overhauling	Difficult

Important Safety Instructions for Installation and Handling

The following signs indicate specific instructions that you should observe for safely installing and handling the rear hatch spoiler.



Warning Failure to follow these instructions could result in serious personal injury or death.



Caution Failure to follow these instructions could result in moderate or slight personal injury or property damage.



Advice Methods and procedures are provided for efficiently installing and handling the rear hatch spoiler.

Requests upon Receipt of the Product



Caution Check the conditions of the product and that all accessory parts are present.
· If you find that the product is defective or faulty upon receipt, or if you have received the wrong product, please contact us at the following address, telephone/fax number, or e-mail address immediately.
If more than a week has passed, your product is outside the scope of our warranty against initial failure.

Before Installing the Product



Caution Please read these instructions thoroughly before installing the product.

- Do not attempt any procedure on the product that is not specifically described in this manual.
Do not attempt to use any part made by other companies, use or modify different alternatives, or install the product on any vehicle other than the supported one.
We hold no responsibility for any damage, accident, or casualty caused by failing to observe the instructions described in this manual.
- The serviceman who installed the product holds no responsibility for replacing it. Read these instructions carefully before installing the product.



Warning Carry out a vehicle safety check before installing the product.

- Do not work on the vehicle while the engine is running, or on hilly uneven ground, or places exposed to chemical products or fire.
- Avoid working on the vehicle immediately after it has come to a stop and wait for the engine, muffler, and braking system to cool down sufficiently before installing the product.
- Make sure to use an automotive lift to raise the vehicle to safely access its bottom.
- Do not attempt to use an automotive jack for this job, as it is dangerous for you and the vehicle.
- Lift the vehicle with a mechanic tool such as rigid racks to ensure your safety, as it is dangerous for you to work on the unstable vehicle.

Contact

JAOS Corporation

ADDRESS: 3586-1, HIROBABA, SHINTO, GUNMA 370-3504 JAPAN TEL. +81-279-20-5511 FAX. +81-279-20-5549
URL : <http://www.jaos.co.jp> E-mail : info@jaos.co.jp

B056250-1

Overhauling



Caution Overhaul the vehicle at a fully furnished auto repair facility.

- Make sure that a certified mechanic will overhaul the vehicle at an auto repair facility approved by the local transportation bureau director, in the event that task difficulty is rated at 4) overhauling.

Safe Installation Recommendations



Caution Follow the instructions described in your car's repair manual to remove and install genuine parts.

- The term genuine parts in this manual are used to refer to standard auto parts manufactured by automakers. Follow the instructions described in your car's repair manual (e.g. a service manual).
- Genuine parts may be reused after removal. Do not have them all mixed up at the time of reassembly and keep them in a safe place to avoid losing them.
- Do not remove any part other than the ones specified in this manual.



Caution Handle the product with care.

- Do not drop or give a strong shock to the product before and during installation. It may deform the product, making installation difficult.
- Be careful not to approach the vehicle while holding the product. You may end up leaving scratches on the car surface.



Caution Perform the task wearing appropriate workwear (coveralls).

- Perform all tasks wearing a pair of coveralls, a hat, a pair of goggles, and a pair of gloves.

Selling or Buying a Used Car, Transferring Ownership or Disposing Of Your Car



Caution Observe the following before selling or buying a used car or transferring ownership of your car to someone.

- At first glance, our products may look the same, but they are categorized into many different types based on the model, year, and grade. We also modify product specifications in accordance with quality enhancements and minor changes on the part of automakers. When selling or buying a used car or transferring ownership of your car to someone, all required items such as mounting brackets, accessories, and documents (the installation manual, the Vehicle Standards (External Projections) certificate, the JASMA muffler registration certificate, etc.) may not be available in many cases. Although many people make inquiries by e-mail or fax accompanying product photos or by telephone, we only can guess and hold no responsibility for the response.
- We now make installation manuals available to download from our website. Note that the content varies depending on the sales period and specification changes. A single product may have different versions of the manual.
- If you find the product defective, stop using it immediately and contact the store you purchased the product from or us.
- Inform the availability of all required items such as accessories and documents when selling a used car or transferring ownership of your car to someone.



Advice Consult a disposal specialist for disposal of the product.

- When disposing of the product or auto parts no longer needed, consult auto repair facility staff or an automotive disassembly company.

Handling Precautions



Caution Perform inspection and maintenance.

- Perform inspection after a long-distance drive or once a month to check if there is any loose or damaged part. Fasten the parts more tightly accordingly.
- If you find the product defective, stop using it immediately and contact the store you purchased the product from or us.



Caution Prevent no chemical products from adhering to the product surface.

- Prevent no oils or fats (braking oil, engine oil, grease, gasoline, and diesel oil) or organic solvents (paint thinners, car battery liquid, etc.) from adhering to the product surface. They may discolor or stain the product. If this happens, immediately wipe the surface with a clean soft cloth or chamois skin dampened with a mild detergent solution and carefully wash the surface down.

About the Product

- Product specifications, its shape and form are subject to change without prior notice, due to enhancements. -

Components

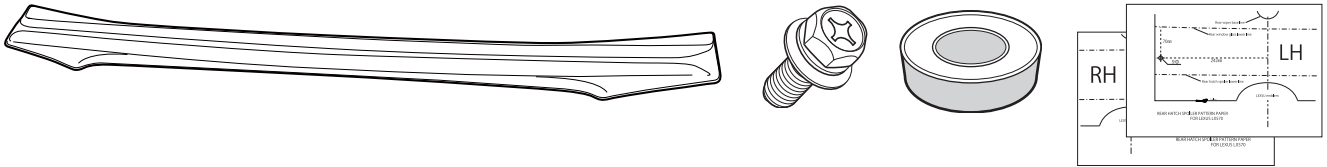

DESCRIPTION	Q'TY	DESCRIPTION	Q'TY
REAR HATCH SPOILER	1	SPONGE WASHER	2
BOLT	2	PATTERN PAPER LH&RH	2

Post-Installation Inspection and Precautions

Check that the rear hatch spoiler is properly installed on the vehicle.

Check that the release liners are all peeled off the double coated tape and the tape is properly attached wherever appropriate.

Check that the rear hatch spoiler and vehicle have no scratches on their respective surfaces after installation is completed.

Do not apply strong force and prevent the rear hatch spoiler and vehicle from getting wet with rain, etc., for a minimum of three hours after installation is completed.

(Otherwise, the double coated tape will peel off, creating space between the rear hatch spoiler and vehicle.)

Coating

Check that installation has been performed properly before coating. Note that we cannot replace the product once it has been coated.

1. Remove stains, such as grease, and dust from the surface you are coating with a clean cloth.
2. Perform primer coating.
3. Perform final coating.
4. Dry the coated surface.



Caution Do not apply the baking finish on the product due to the nature of the material and perform baking at ambient temperatures or with the product surface temperature being maintained at 30 to 40°C after performing sanding treatment.

Installation Procedures

Circled numbers in the illustration and paragraphs represent the product components.

1. Remove inside genuine cover of back door.

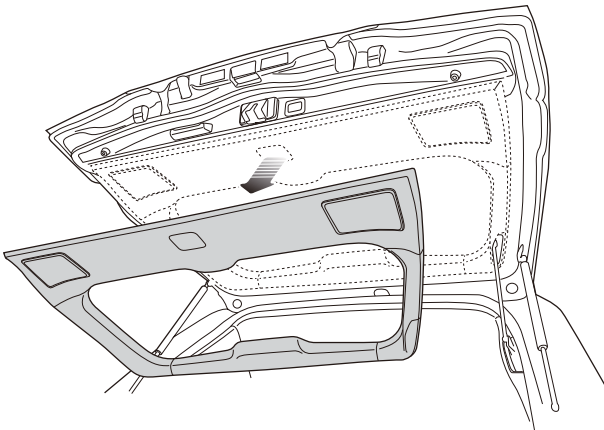

1. Remove inside genuine cover of back door.

2. Place pattern paper

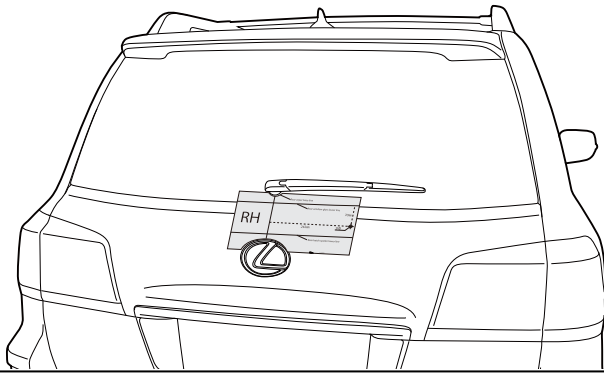

1. Cut pattern paper .
2. Place pattern paper with masking tape.
3. Mark hole position.

3. Drilling holes

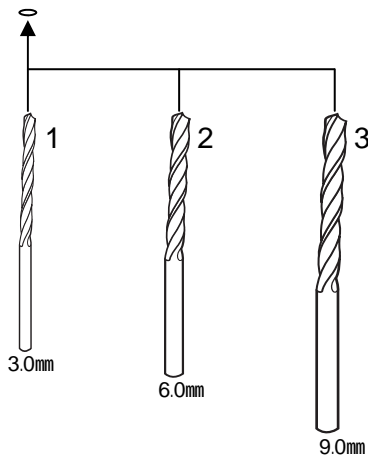

1. Drilling holes using 3.0mm, 6.0mm and 9.0mm drill bits.

4. Temporary mounting and grease removal

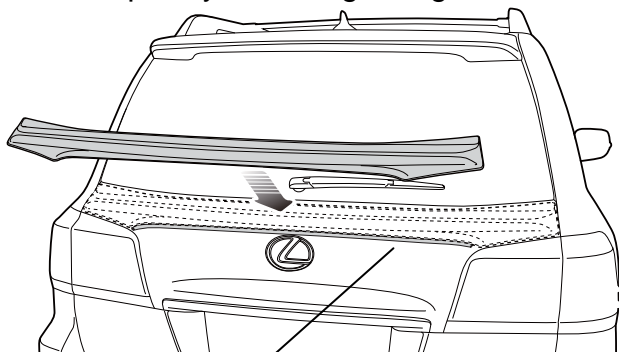

Masking tape, etc.

1. Align the rear hatch spoiler with the genuine rear hatch and confirm the mounting locations as well as where to attach the double coated tape.



Caution • Align the rear hatch spoiler along the top edge of end molding.



Advice • Mark the mounting locations with the masking tape for confirmation.

2. Remove the rear hatch spoiler and get rid of grease on the adhesive side of the double coated tape.

5. Mounting preparations

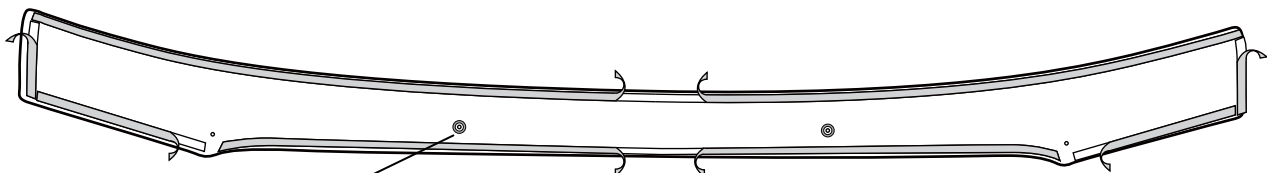

Sponge Washer

1. Peel the release liners off the double coated tape taped on the rear hatch spoiler .
2. Attach the sponge washer to the location indicated in the illustration.

6. Mounting

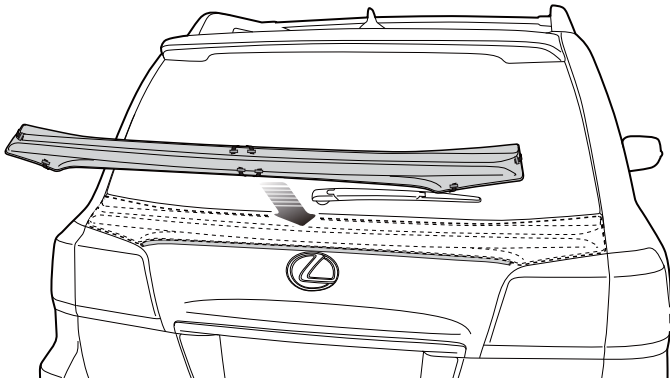

1. Align the rear hatch spoiler with the pre-confirmed mounting locations.

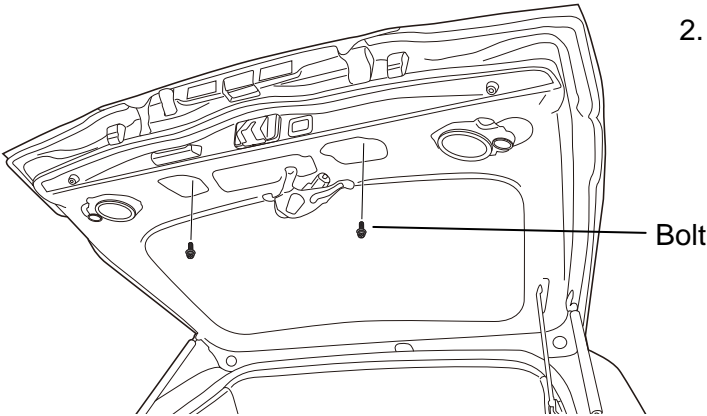

2. Fasten the sides of the rear hatch spoiler temporarily with the bolt.

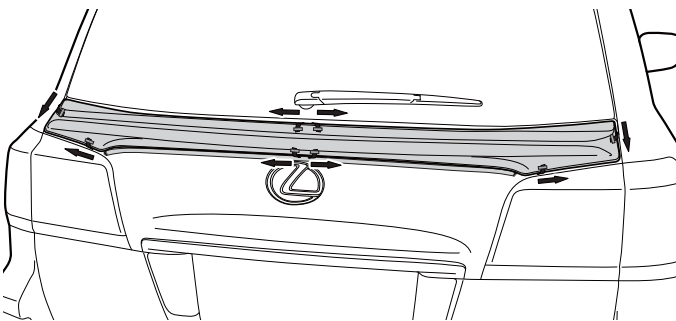

3. Attach the double coated tape by pulling off the release liners in the arrow pointing directions, as shown in the illustration to the left.



Caution • Make sure to maintain the mounting height of the rear hatch spoiler when pulling off the release liners.



Advice • Raise the rear hatch spoiler slightly in order not to tear off the release liners halfway.
• Press the double coated tape with a force of approximately 500 kPa (5kgf/cm²).

4. Press the double coated tape firmly again to make good contact all the way.
5. Wait more than three hours after attaching the double coated tape to permanently mount the temporarily mounted rear hatch spoiler.
6. Mount the genuine cover of back door.